

# 500-1100 e-FOB System (Unsealed, Discrete)



## **510-0100 e-FOB Receiver (Unsealed)**

- Increased end user convenience
- Easy and intuitive to operate
- Rugged and durable construction
- Compliant to on-road, off-road, and industrial environmental requirements
- Increased vehicle security with multiple triggers and outputs
- Includes on-board locking and unlocking relays for up to four actuators
- Numerous entry/compartament doors
- Locking/unlocking confirmation
- Ignition controlled auto-locking
- Starter deactivation available for increased security
- Lighting and auxiliary output control
- Panic mode outputs
- Valet mode
- Reliable radio frequency (RF) transmission
- FCC-Part 15 compliant
- Complete kit with wire harnesses and other accessories
- High security with code hopping technology

## **530-0100 e-FOB Transmitter:**

- Reliable radio frequency (RF) transmission
- High security with code hopping technology
- Compliant to FCC-Part 15 and EU RF requirements
- 4-button standard fob (other configurations available)
- Customized graphics possible (buttons and logos)
- Can add up to 20 fob transmitters per vehicle

### **DESIGNED FOR:**

- TriMark's e-ASK systems consist of a selection of compatible components that allow for complete keyless entry for on or off-highway vehicle applications
- Incorporation into TriMark mechanical latches, handles and systems by providing keyless entry, security and convenience for access door systems through a RF remote fob electronics interface

### **Global Locations:**

**TriMark Corporation**  
500 Bailey Avenue  
P.O. Box 350  
New Hampton, Iowa 50659  
United States  
Tel: 641-394-3188  
Fax: 641-394-2392  
1-800-447-0343  
www.trimarkcorp.com

**TriMark Europe**  
Unit 3  
Sence Court  
Bardon Hill  
Coalville LE67 1GZ  
United Kingdom  
Tel: +44(0)1530 512460  
Fax: +44(0)1530 512461  
www.trimarkeu.com

**TriMark (Xuzhou)**  
Building A5 Jingwu Road  
Xuzhou Economic  
Development Zone  
Xuzhou, Jiangsu  
221004 PR China  
Tel: +86 516 8773 0018  
Fax: +86 516 8773 0058  
www.trimarkcn.com



TriMark. Interactive. Product. Selector



TriMark



TriMark Corporation



TriMark Corporation

### AVAILABLE:

- Standard kit make up includes: (2) pre-trained RF remote fob transmitters, RF receiver, (14) wire harness, (10) wire harness, (2) wire harness, push button switch, and LED assembly key rings and manual
- Optional kits can include: extra relays, switches, door contacts, actuators, mounting hardware, mounting brackets, door latches, and door paddle handles
- Customized wire harnesses
- High security with code hopping technology
- 4-button standard fob
- Customized graphics possible (buttons and logos - please inquire)
- Can add up to 4 fob transmitters to vehicle

### INSTALLATION:

- I/O module is easily installed with (2) #10 or M5 Fastener (not included) and can be mounted in a concealed location
- Keypad is easy to install with (2) #8 or M4 flat head screws (not included)
- Keypad can be installed in a wide range of locations in door — either horizontal or vertical orientation
- Standard 12V DC power
- Easy to install and program

Please refer to individual product codes and part drawings for complete dimensions, specifications, installation procedures, and related items. Engineering assistance and application drawings are available.

Design Patent No. D590,780 / D589,000

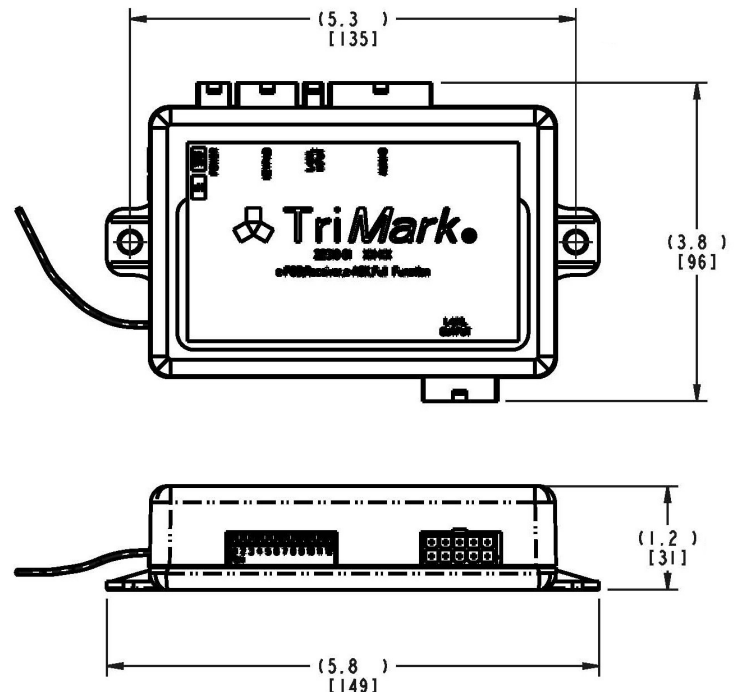
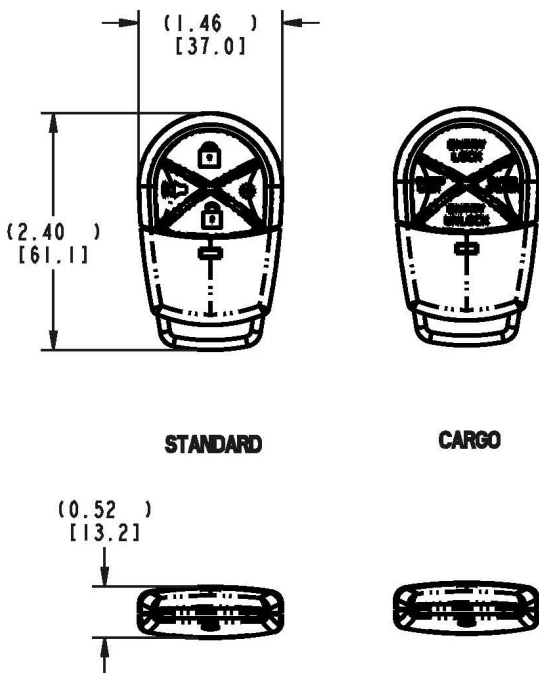

- Three different programming functions; standard mode, cargo mode and sustained mode. Modes provide customized remote fob transmitter use. Standard mode allows for the lock/unlocking of doors plus panic mode and one auxiliary output (controls lighting, opens compartment etc). Cargo mode allows for the lock/unlocking of main personnel doors plus independent control of many cargo/compartments doors. Sustained mode allows for the lock/unlocking of doors plus continuous output control with lower buttons pressing.

For more information visit:  
[www.trimarkcorp.com](http://www.trimarkcorp.com)

### WARNING:

Immediately dispose of used batteries and keep away from children. Do NOT dispose of batteries in household trash.

Even used batteries may cause severe injury or death.

Call a local poison control center for treatment information.

<b>⚠ WARNING</b>	
<ul style="list-style-type: none"> <li>• <b>INGESTION HAZARD:</b> This product contains a button cell or coin battery.</li> <li>• <b>DEATH</b> or serious injury can occur if ingested.</li> <li>• A swallowed button cell or coin battery can cause <b>Internal Chemical Burns</b> in as little as <b>2 hours</b>.</li> <li>• <b>KEEP</b> new and used batteries <b>OUT OF REACH</b> of CHILDREN</li> <li>• <b>Seek immediate medical attention</b> if a battery is suspected to be swallowed or inserted inside any part of the body.</li> </ul>	